



CITY OF MILLBRAE

621 MAGNOLIA AVENUE
MILLBRAE, CA 94030
PH: (650) 259-2339; Fax: (650) 697-8158

APPLICATION TO DISPLAY BANNER OVER BROADWAY

Name of Sponsoring Organization

Complete Mailing Address

Name of Authorized Contact Person

()

Phone Number

E-mail Address

Proposed Message on Banner

From: _____ To: _____
Dates Requested for Banner Display (day, month, year)

Evidence of general liability insurance of at least \$1,000,000.00 attached: YES NO

I the undersigned, certify that I have read and understand the conditions for displaying a banner and the specification requirements (on reverse) for a banner, and that the banner covered by this application meets the specification requirements. If it is found that the banner does not meet the specification requirements, I understand the banner will be returned to me and the application voided. It is further understood that the banner is to be picked up by me or a representative within **7 Calendar Days** after the date noted below, or any other date with written notification from the City. The City will dispose of the banner in any manner which the City determines appropriate without further notification.

Signature of Application

Date of Application

Approved/Denied

Date of Review

CC:

- City Administrator
- Director of Public Works
- Superintendent of Public Works
- Applicant

**Return completed application to:
Charmaine Wright
Email: cwright@ci.millbrae.ca.us
Fax: 650-697-8158**

Date if Banner to be brought to City Hall

Date of Banner to be Picked up by Street Staff

Date of Banner to be Returned to City Hall by Street Staff

Date Banner to be Picked up at City Hall

Banner Meets City of Millbrae Specifications

Yes No



CITY OF MILLBRAE

621 MAGNOLIA AVENUE

MILLBRAE, CA 94030

PH: (650) 259-2339; Fax: (650) 697-8158

WAIVER AND RELEASE OF LIABILITY FOR BANNER DISPLAY

In consideration of permission granted by the City of Millbrae ("City") authorizing _____ and its directors, employees, representatives, agents and volunteers (Collectively: "Applicant") to construct and display a banner, to be hung and removed by city staff, Across Broadway Avenue near Hillcrest Boulevard from _____, 20__ to _____, 20__ hereinafter referred to as "Activity"), Applicant hereby agrees as follows:

1. Applicant shall construct the banner in the method and using the materials specified in the City's Requirements for such banners. City staff will hand and remove the banner to Applicant.
2. Applicant shall not make a claim, sue, or maintain any legal action against and hereby released and discharges, the City, its Councilmembers, employees, agents and representatives from any and all claim, demands, damages, causes of action and liabilities resulting from or arising out of the Activity. Applicant expressly waives the benefits of California Civil Code Section 1542, which provides:

A general release does not extend to claims which the creditor does not know or suspect to exist in his favor at the time of executing the release, which if know by him must have materially effected his settlement with the debtor.

Applicant understands and acknowledges that the significance of this waiver of California Civil Code Section 1542 is that even if application should eventually suffer additional damage arising out of the Activity, Applicant will not be able to make any claim for those damages.

3. Applicant shall indemnify, defend (with counsel reasonably satisfactory to City) and hold harmless the City, its Council members, employees, agents and representatives from and against all claims, losses, demands, damages, causes of action and liabilities of e very kind (including reasonable attorney's fees) for injury to or death of ay persons or for loss of or damage to any property arising out of or in connection with the activity.
4. Applicant shall procure and maintain throughout the period that the banner is displayed, at its sole cost and expense, general liability insurance with a limit of liability not less than one million dollars (\$1,000,000.00) per occurrence. The policy shall include a stipulation that the city, its council members, employees, agents and representatives are additional insureds. Prior to the hanging of the banner, Applicant shall submit a Certificate of Insurance to the City evidencing such coverage and stipulating that the policy is Primary Insurance and the insurance company providing the policy shall be liable thereunder for the full amount of any loss of claim which applicant is liable for, up to and including the total limit liability, without right of contribution from any other insurance effected by City.

Date: _____

Applicant

(Signed by Applicant's Authorized Representatives)

(Printed Name)

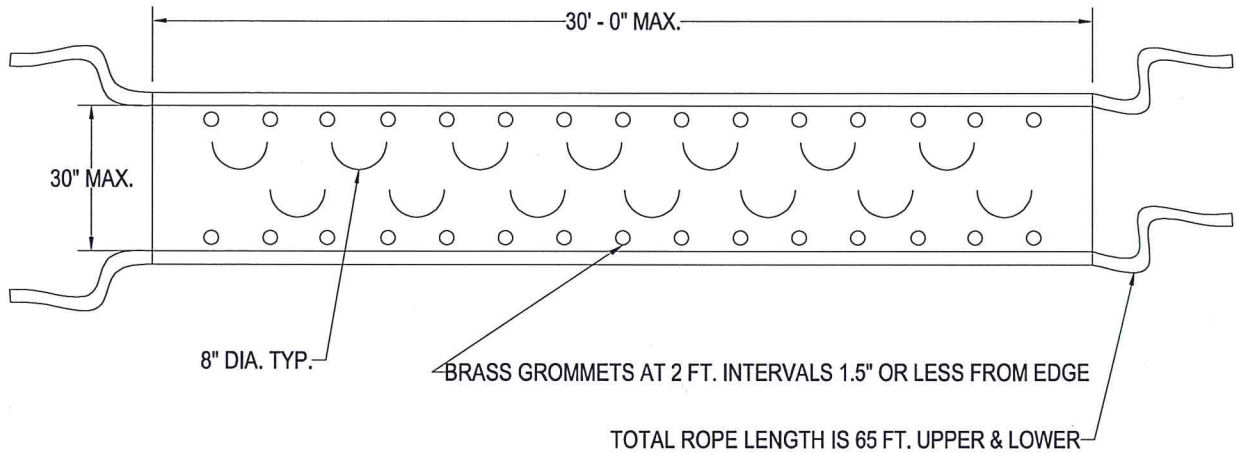

SPECIFICATIONS

1. BANNERS SHALL BE CONSTRUCTED OF COTTON, NYLON OR VINYL COVERED FABRIC. THE TOTAL WEIGHT OF THE BANNER WITH ALL FITTINGS AND ROPES SHALL NOT EXCEED 25 POUNDS.
2. THE BANNER SHALL HAVE NO LESS THAN 25 WIND RELIEF HOLES. THEY SHALL BE 8" DIAMETER SEMICIRCLES DISTRIBUTED EVENLY OVER THE SURFACE OF THE BANNER.
3. A $\frac{1}{4}$ " TO $\frac{3}{8}$ " BRAIDED NYLON OR HEMP ROPE SHALL BE SEWN INTO THE TOP AND BOTTOM OF THE BANNER. THE TOTAL LENGTH OF EACH ROPE SHALL BE 65 FEET.
4. BRASS $\frac{3}{4}$ " GROMMETS SHALL BE PLACED AT 2 FT. INTERVALS BEHIND BOTH THE TOP AND BOTTOM ROPES. NO MORE THAN 1.5" FROM EDGE.

NO BANNER WILL BE INSTALLED THAT DOES NOT MEET THE ABOVE SPECIFICATIONS. BECAUSE OF THE SAFETY HAZARD, THERE WILL BE NO EXCEPTIONS.

BANNER DISPLAY TIME IS ONE (1) WEEK WITH A ONE WEEK EXTENSION FOR SPECIAL CASES AS DETERMINED BY THE CITY OF MILLBRAE PUBLIC WORKS DEPARTMENT.

CITY OF MILLBRAE * STANDARD PLANS

NO.	REVISIONS	DATE	PROMOTIONAL BANNER DETAIL				APPROVED				
							<div style="text-align: right; margin-right: 20px;"> _____ City Engineer </div>				
DRAWN	SC	CHECKED	KL	DATE	11/18/15	SCALE	NONE	SHEET	1 OF 1	DWG. NO.	N/A